

SECTION THRU BASIN & FILTER

INLET SHALL BE PROTECTED (AS NEEDED) FROM EROSION WITH RIPRAP, TARP, MATTING OR EQUIVALENT.

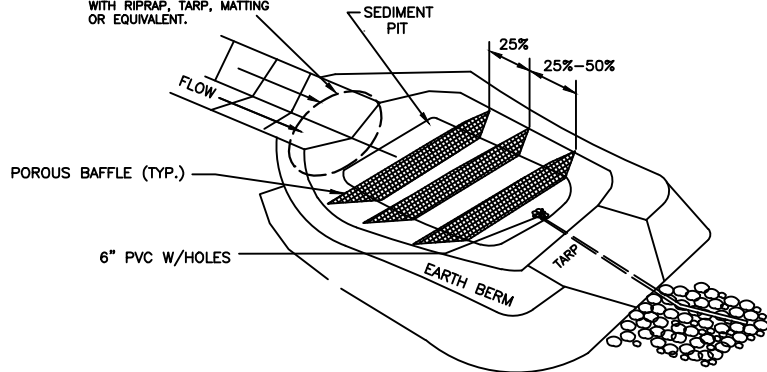

PERSPECTIVE VIEW

GENERAL NOTES

1. DRAW DOWN RISER & BARREL SHALL BE 6" SCH. 40 PVC WITH CLEAN-OUT CAP AND 3/4" HOLES. SEE NOTE 1 FOR NUMBER AND SPACING OF HOLES.
2. THE TARP USED TO PROTECT THE WEIR SHALL BE THE WIDTH SPECIFIED. THE LENGTH OF THE TARP SHALL BE ACCORDING TO AVAILABLE SUPPLY. IF MULTIPLE TARPS ARE TO BE USED, THEN TARPS SHALL BE OVERLAPPED AT LEAST 12". THE UPSTREAM 12" TARP SHALL OVERLAP THE DOWNSTREAM TARP. THE TARP SHALL BE 50 MIL. HEAVY DUTY SILVER TARPULINS OR EQUIVALENT FOR U.V. RESISTANCE.
3. MAINTENANCE: SEDIMENT TO BE REMOVED AND PROPERLY DISPOSED OF WHEN BASIN IS HALF FULL. GRAVEL FILTER AROUND RISER SHOULD BE REPLACED AS NEEDED TO ENSURE DEWATERING.

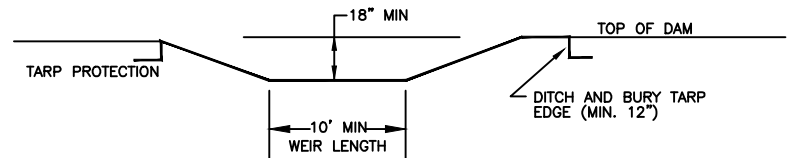

SECTION THRU WEIR

NOTE 1

HOLE SPECS:

DEWATERING HOLES WILL BE INSTALLED IN SETS OF HORIZONTAL RINGS. THE FIRST SET OF HOLES WILL BE SET 6 INCHES FROM THE BOTTOM OF THE RISER. RINGS WILL CONTINUE UP THE RISER IN INTERVALS OF 3 INCHES. HOLES WILL BE 3/4 INCH IN DIAMETER AND WILL BE SPACED EQUALLY AROUND THE RISER. THE NUMBER OF HOLES PER RING WILL EQUAL TO THE DRAINAGE AREA.

EXAMPLE

A BASIN DRAINING 2.0 ACRES SHOULD HAVE 2 HOLES PER RING EVERY 3 INCHES ON THE RISER PIPE. THE FIRST RING (2 HOLES) WILL BE SET 6 INCHES FROM THE BOTTOM OF THE RISER.

NOTE: ROUND DRAINAGE AREA TO THE NEAREST WHOLE NUMBER TO DETERMINE NUMBER OF HOLES.



STANDARD CUSTOM BASIN

EFFECTIVE: 01/31/08